

# How Are Waffles & Running Shoes Connected?

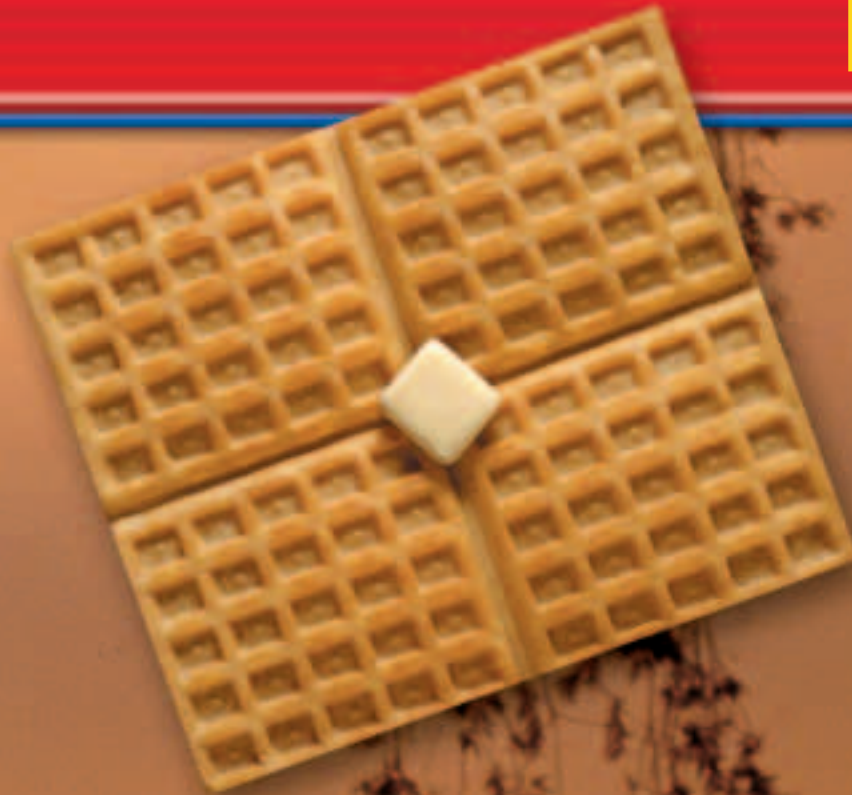



For centuries, shoes were made mostly of leather, cloth, or wood. These shoes helped protect feet, but they didn't provide much traction on slippery surfaces. In the early twentieth century, manufacturers began putting rubber on the bottom of canvas shoes, creating the first "sneakers." Sneakers provided good traction, but the rubber soles could be heavy—especially for athletes. One morning in the 1970s, an athletic coach stared at the waffles on the breakfast table and had an idea for a rubber sole that would be lighter in weight but would still provide traction. That's how the first waffle soles were born. Waffle soles soon became a world standard for running shoes.

**unit**  **projects**

Visit [gpscience.com/unit\\_project](http://gpscience.com/unit_project) to find project ideas and resources.

Projects include:

- **Career** Explore the field of mechanical engineering through sports. Create an advertisement for your aerodynamic sports equipment.
- **Technology** Create a brochure showing five different shoe treads with reference to particular sports and environmental conditions.
- **Model** Design and build a Rube Goldberg machine with at least 20 steps to complete a simple task using physics principles.



Using virtual programming, *Roller Coaster Physics* provides an opportunity to engineer, test, and evaluate roller coaster design, and then build your own 3-dimensional coaster.

(bkgd.)John Terence Turner/FPG/Getty Images, (tl)Artville, (br)Charles L. Perrin



# The Nature of Science

## chapter preview

### sections

- 1 The Methods of Science**
- 2 Standards of Measurement**
- 3 Communicating with Graphs**
  - Lab** *Converting Kitchen Measurements*
  - Lab** *Setting High Standards for Measurements*
  - Virtual Lab** *How is a controlled experiment performed?*

## Out of This World

The space program was developed in response to many unanswered questions. Scientists have worked together to develop ways in which to answer those questions. In this chapter, you will learn how scientists learn about the natural world.

**Science Journal** Look at the picture above. Write in your Science Journal why scientists study space.

# Start-Up Activities



## Understanding Measurements

During a track meet, one athlete ran 1 mile in 5 min and another athlete ran 5,000 m in 280 s. The two runners used different units to describe their races, so how can you compare them? Do the following lab to explore how using different units can make it difficult to compare measurements.

1. Measure the distance across your classroom using your foot as a measuring device.
2. Record your measurement and name your measuring unit.
3. Now, have your partner measure the same distance using his or her foot as the measuring device. Record this measurement and make up a different name for the unit.
4. **Think Critically** Explain why you think it might be important to have standard, well-defined units to make measurements.



Preview this chapter's content and activities at [gpscience.com](http://gpscience.com)



**Scientific Processes** Make the following Foldable to help identify what you already know, what you want to know, and what you learned about science.

- STEP 1** **Fold** a vertical sheet of paper from side to side. Make the front edge about 1.25 cm shorter than the back edge.

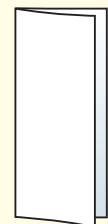

- STEP 2** **Turn** lengthwise and **fold** into thirds.

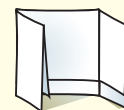

- STEP 3** **Unfold and cut** only the top layer along both folds to make three tabs. **Label** each tab.



**Identify Questions** Before you read the chapter, write what you already know about science under the left tab of your Foldable, and write questions about what you'd like to know under the center tab. After you read the chapter, list what you learned under the right tab.



# The Methods of Science

## Reading Guide

### What You'll Learn

- **Identify** the steps scientists often use to solve problems.
- **Describe** why scientists use variables.
- **Compare and contrast** science and technology.

### Why It's Important

Using scientific methods will help you solve problems.

#### Review Vocabulary

**investigation:** to observe or study by close examination

### New Vocabulary

- scientific method
  - hypothesis
  - experiment
  - variable
  - dependent variable
  - independent variable
- constant
  - control
  - bias
  - model
  - theory
  - scientific law
  - technology

## What is science?

Science is not just a subject in school. It is a method for studying the natural world. After all, science comes from the Latin word *scientia*, which means “knowledge.” Science is a process that uses observation and investigation to gain knowledge about events in nature.

Nature follows a set of rules. Many rules, such as those concerning how the human body works, are complex. Other rules, such as the fact that Earth rotates about once every 24 h, are much simpler. Scientists ask questions to learn about the natural world.

**Major Categories of Science** Science covers many different topics that can be classified according to three main categories. (1) Life science deals with living things. (2) Earth science investigates Earth and space. (3) Physical science deals with matter and energy. In this textbook, you will study mainly physical science. Sometimes, though, a scientific study will overlap the categories. One scientist, for example, might study the motions of the human body to understand how to build better artificial limbs. Is this scientist studying energy and matter or how muscles operate? She is studying both life science and physical science. It is not always clear what kind of science you are using, as shown in **Figure 1**.

**Figure 1** Astronaut Michael Lopez-Alegria uses a pistol grip tool on the *International Space Station*.

**Observe** What evidence do you see of the three main branches of science in the photograph?



**Science Explains Nature** Scientific explanations help you understand the natural world. Sometimes these explanations must be modified. As more is learned about the natural world, some of the earlier explanations might be found to be incomplete or new technology might provide more accurate answers.

For example, look at **Figure 2**. In the late eighteenth century, most scientists thought that heat was an invisible fluid with no mass. Scientists observed that heat seemed to flow like a fluid. It also moves away from a warm body in all directions, just as a fluid moves outward when you spill it on the floor.

However, the heat fluid idea did not explain everything. If heat were an actual fluid, an iron bar that had a temperature of  $1,000^{\circ}\text{C}$  should have more mass than it did at  $100^{\circ}\text{C}$  because it would have more of the heat fluid in it. The eighteenth-century scientists thought they just were not able to measure the small mass of the heat fluid on the balances they had. When additional investigations showed no difference in mass, scientists had to change the explanation.

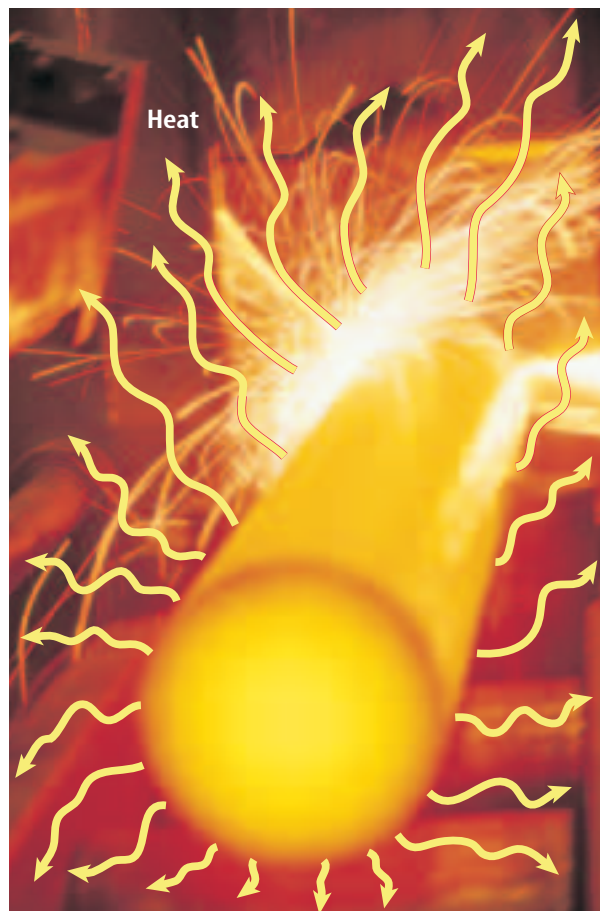

**Figure 2** Many years ago, scientists thought that heat, such as in this metal rod, was a fluid.

**Infer** how heat acts like a fluid.

**Investigations** Scientists learn new information about the natural world by performing investigations, which can be done many different ways. Some investigations involve simply observing something that occurs and recording the observations, perhaps in a journal. Other investigations involve setting up experiments that test the effect of one thing on another. Some investigations involve building a model that resembles something in the natural world and then testing the model to see how it acts. Often, a scientist will use something from all three types of investigation when attempting to learn about the natural world.

**Reading Check** Why do scientific explanations change?

## Scientific Methods

Although scientists do not always follow a rigid set of steps, investigations often follow a general pattern. An organized set of investigation procedures is called a **scientific method**. Six common steps found in scientific methods are shown in **Figure 3**. A scientist might add new steps, repeat some steps many times, or skip steps altogether when doing an investigation.

**ScienceOnline**

### Topic: Prediction

Visit [gpscience.com](http://gpscience.com) for Web links to information about why leaves change color in the autumn.

**Activity** Fill a glass with cold water and add a few drops of blue or red food coloring. Cut a piece of celery and place it in the glass. Over the next few days observe what happens to the celery. Make a prediction about why this occurs. Support your answer with evidence.

**Figure 3** The series of procedures shown here is one way to use scientific methods to solve a problem.

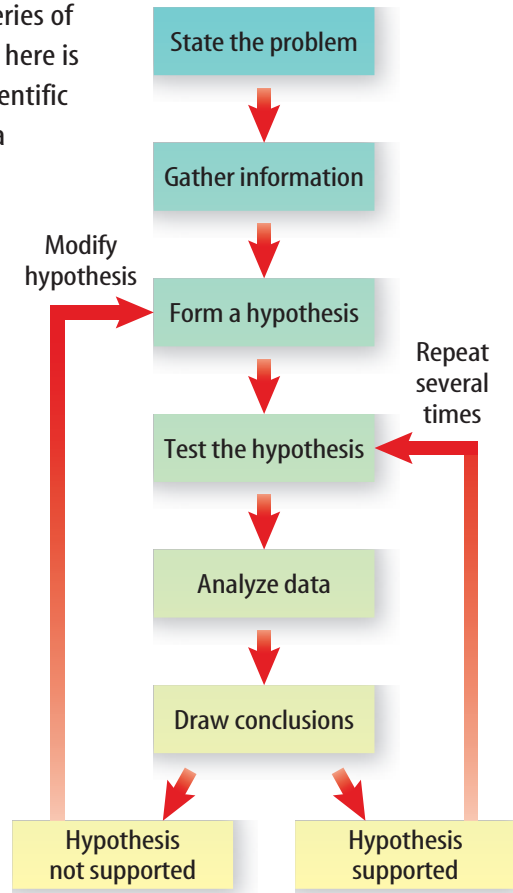

**Stating a Problem** Many scientific investigations begin when someone observes an event in nature and wonders why or how it occurs. Then the question of “why” or “how” is the problem. Sometimes a statement of a problem arises from an activity that is not working. Some early work on guided missiles showed that the instruments in the nose of the missiles did not always work. The problem statement involved finding a material to protect the instruments from the harsh conditions of flight.

Later, National Aeronautics and Space Administration (NASA) scientists made a similar problem statement. They wanted to build a new vehicle—the space shuttle—that could carry people to outer space and back again. Guided missiles did not have this capability. NASA needed to find a material for the outer skin of the space shuttle that could withstand the heat and forces of reentry into Earth’s atmosphere.

**Researching and Gathering Information** Before testing a hypothesis, it is useful to learn as much as possible about the background of the problem. Have others found information that will help determine what tests to do and what tests will not be helpful? The NASA scientists gathered information about melting points and other properties of the various materials that might be used. In many cases, tests had to be performed to learn the properties of new, recently created materials.

**Forming a Hypothesis** A **hypothesis** is a possible explanation for a problem using what you know and what you observe. NASA scientists knew that a ceramic coating had been found to solve the guided missile problem. They hypothesized that a ceramic material also might work on the space shuttle.

**Testing a Hypothesis** Some hypotheses can be tested by making observations. Others can be tested by building a model and relating it to real-life situations. One common way to test a hypothesis is to perform an experiment. An **experiment** tests the effect of one thing on another using controlled conditions.



**Variables** An experiment usually contains at least two variables. A **variable** is a quantity that can have more than a single value. You might set up an experiment to determine which of three fertilizers helps plants to grow the biggest. Before you begin your tests, you would need to think of all the factors that might cause the plants to grow bigger. Possible factors include plant type, amount of sunlight, amount of water, room temperature, type of soil, and type of fertilizer.

In this experiment, the amount of growth is the **dependent variable** because its value changes according to the changes in the other variables. The variable you change to see how it will affect the dependent variable is called the **independent variable**.

**Constants and Controls** To be sure you are testing to see how fertilizer affects growth, you must keep the other possible factors the same for each test, or trial. A factor that does not change when other variables change is called a **constant**. You might set up four trials, using the same soil and type of plant. Each plant is given the same amount of sunlight and water and is kept at the same temperature. These are constants. Three of the plants receive a different type of fertilizer. Fertilizer is the independent variable.

The fourth plant is not fertilized. This plant is a control. A **control** is the standard by which the test results can be compared. Suppose that after several days, the three fertilized plants grow between 2 and 3 cm. If the unfertilized plant grows 1.5 cm, you might infer that the growth of the fertilized plants was due to the fertilizers.

How might the NASA scientists set up an experiment to solve the problem of the damaged tiles shown in **Figure 4**? What are possible variables, constants, and controls?

 **Reading Check** *Why is a control used in an experiment?*

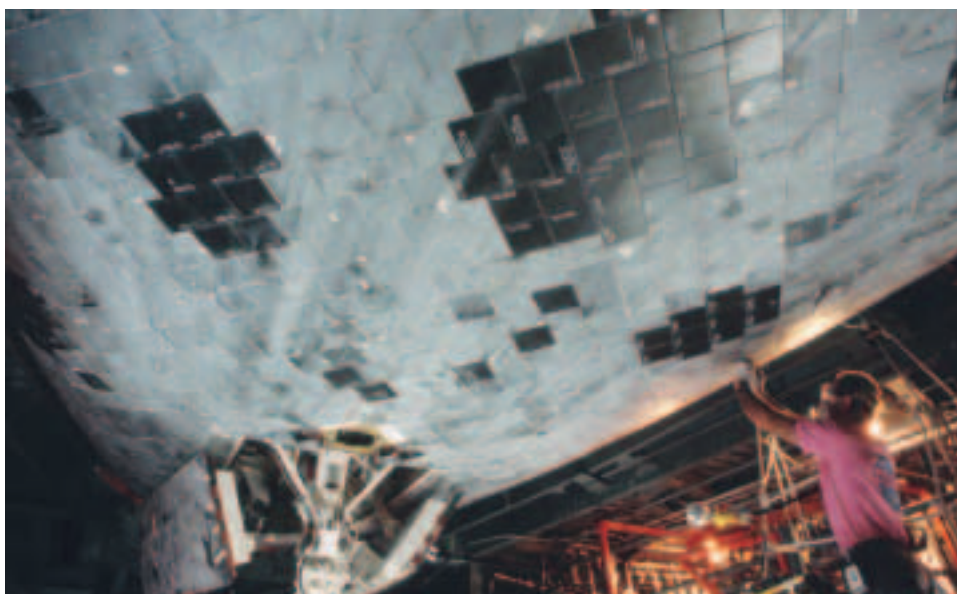

### Classification Systems

Through observations of living organisms, Aristotle designed a classification system. Systems used today group organisms according to variables such as habits and physical and chemical features. Research to learn recent reclassifications of organisms. Share your findings with your class.

**Figure 4** NASA has had an ongoing mission to improve the space shuttle. A technician is replacing tiles damaged upon reentry into Earth's atmosphere.





**Figure 5** An exciting and important part of investigating something is sharing your ideas with others, as this student is doing at a science fair.

**Analyzing the Data** An important part of every experiment includes recording observations and organizing the test data into easy-to-read tables and graphs. Later in this chapter you will study ways to display data. When you are making and recording observations, you should include all results, even unexpected ones. Many important discoveries have been made from unexpected occurrences.

Interpreting the data and analyzing the observations is an important step. If the data are not organized in a logical manner, wrong conclusions can be drawn. No matter how well a scientist communicates and shares that

data, someone else might not agree with the data. Scientists share their data through reports and conferences. In **Figure 5** a student is displaying her data.

**Drawing Conclusions** Based on the analysis of your data, you decide whether or not your hypothesis is supported. When lives are at stake, such as with the space shuttle, you must be very sure of your results. For the hypothesis to be considered valid and widely accepted, the experiment must result in the exact same data every time it is repeated. If your experiment does not support your hypothesis, you must reconsider the hypothesis. Perhaps it needs to be revised or your experiment needs to be conducted differently.

**Being Objective** Scientists also should be careful to reduce bias in their experiments. A **bias** occurs when what the scientist expects changes how the results are viewed. This expectation might cause a scientist to select a result from one trial over those from other trials. Bias also might be found if the advantages of a product being tested are used in a promotion and the drawbacks are not presented.

Scientists can lessen bias by running as many trials as possible and by keeping accurate notes of each observation made. Valid experiments also must have data that are measurable. For example, a scientist performing a global warming study must base his or her data on accurate measures of global temperature. This allows others to compare the results to data they obtain from a similar experiment. Most importantly, the experiment must be repeatable. Findings are supportable when other scientists perform the same experiment and get the same results.

 **Reading Check** *What is bias in science?*

(l)Roger Ressmeyer/CORBIS, (r)Douglas Mesney/The Stock Market/CORBIS

## Visualizing with Models

Sometimes, scientists cannot see everything that they are testing. They might be observing something that is too large, too small, or takes too much time to see completely. In these cases, scientists use models. A **model** represents an idea, event, or object to help people better understand it.

**Models in History** Models have been used throughout history. One scientist, Lord Kelvin, who lived in England in the 1800s, was famous for making models. To model his idea of how light moves through space, he put balls into a bowl of jelly and encouraged people to move the balls around with their hands. Kelvin's work to explain the nature of temperature and heat still is used today.

**High-Tech Models** Scientific models don't always have to be something you can touch. Today, many scientists use computers to build models. NASA experiments involving space flight would not be practical without computers. The complex equations would take far too long to calculate by hand, and errors could be introduced much too easily.

Another type of model is a simulator, like the one shown in **Figure 6**. An airplane simulator enables pilots to practice problem solving with various situations and conditions they might encounter when in the air. This model will react the way a plane does when it flies. It gives pilots a safe way to test different reactions and to practice certain procedures before they fly a real plane.



### Computer Models

Meteorology has changed greatly due to computer modeling. Using special computer programs, meteorologists now are able to more accurately predict disastrous weather. In your Science Journal, describe how computer models might help save lives.

**Figure 6** Pilots and astronauts use flight simulators for training. **Explain** how these models differ from actual airplanes and spacecraft.





### Topic: Archimedes' Principle

Visit [gpscience.com](http://gpscience.com) for Web links to information about Archimedes' principle.

**Activity** Place a full soft-drink bottle, water bottle, or container of milk in a tub of water. What happens to the pop bottle or milk container? Would you classify Archimedes' principle as a scientific theory or scientific law?

## Scientific Theories and Laws

A scientific **theory** is an explanation of things or events based on knowledge gained from many observations and investigations. It is not a guess. If scientists repeat an investigation and the results always support the hypothesis, the hypothesis can be called a theory. Just because a scientific theory has data supporting it does not mean it will never change. Recall that the theory about heat being a fluid was discarded after further experiments. As new information becomes available, theories can be modified. A theory accepted today might at some time in the future also be discarded.

A **scientific law** is a statement about what happens in nature and that seems to be true all the time. Laws tell you what will happen under certain conditions, but they don't explain why or how something happens. Gravity is an example of a scientific law. The law of gravity says that any one mass will attract another mass. To date, no experiments have been performed that disprove the law of gravity.

A theory can be used to explain a law. For example, many theories have been proposed to explain how the law of gravity works. Even so, there are few theories in science and even fewer laws.

**Figure 7** Science can't answer all questions.

**Analyze** Can anyone prove that you like artwork? Explain.

### Reading Check

What is the difference between a scientific theory and a scientific law?



## The Limitations of Science

Science can help you explain many things about the world, but science cannot explain or solve everything. Although it's the scientist's job to make guesses, the scientist also has to make sure his or her guesses can be tested and verified. But how do you prove that people will like a play or a piece of music? You cannot and science cannot.

Most questions about emotions and values are not scientific questions. They cannot be tested. You might take a survey to get people's opinions about such questions, but that would not prove that the opinions are true for everyone. A survey might predict that you will like the art in **Figure 7**, but science cannot prove that you or others will.

## Using Science—Technology

Many people use the terms *science* and *technology* interchangeably, but they are not the same. **Technology** is the application of science to help people. For example, when a chemist develops a new, lightweight material that can withstand great amounts of heat, science is used. When that material is used on the space shuttle, technology is applied. **Figure 8** shows other examples of technology.

Technology doesn't always follow science, however. Sometimes the process of discovery can be reversed. One important historic example of science following technology is the development of the steam engine. The inventors of the steam engine had little idea of how it worked. They just knew that steam from boiling water could move the engine. Because the steam engine became so important to industry, scientists began analyzing how it worked. Lord Kelvin, James Prescott Joule and Sadi Carnot, who lived in the 1800s, learned so much from the steam engine that they developed revolutionary ideas about the nature of heat.

Science and technology do not always produce positive results. The benefits of some technological advances, such as nuclear technology and genetic engineering, are subjects of debate. Being more knowledgeable about science can help society address these issues as they arise.

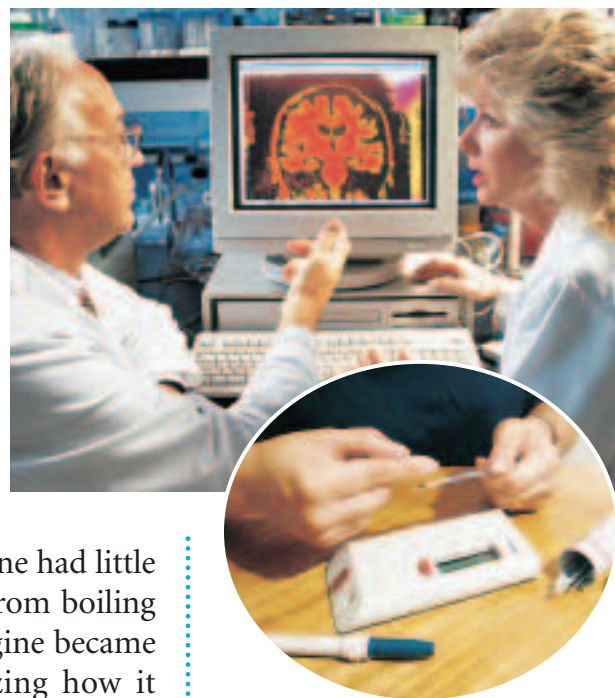

**Figure 8** Technology is the application of science.

**State** the type of science (*life, Earth, or physical*) that is applied in these examples of technology.

### section 1 review

#### Summary

##### What is science?

- Scientists ask questions and perform investigations to learn more about the natural world.

##### Scientific Methods

- Scientists perform the six-step scientific method to test their hypotheses.

##### Visualizing with Models

- Models help scientists visualize concepts.

##### Scientific Theories and Laws

- A theory is a possible explanation for observations while a scientific law describes a pattern but does not explain why things happen.

##### Using Science—Technology

- Technology is the application of science into our everyday lives.

#### Self-Check

1. **Define** the first step a scientist usually takes to solve a problem.
2. **Explain** why a control is needed in a valid experiment.
3. **Think Critically** What is the dependent variable in an experiment that shows how the volume of gas changes with changes in temperature?

#### Applying Math

4. **Find the Average** You perform an experiment to determine how many breaths a fish takes per minute. Your experiment yields the following data: minute 1: 65 breaths; minute 2: 73 breaths; minute 3: 67 breaths; minute 4: 71 breaths; minute 5: 62 breaths. Calculate the average number of breaths that a fish takes per minute.



# Standards of Measurement

## Reading Guide

### What You'll Learn

- **Name** the prefixes used in SI and indicate what multiple of ten each one represents.
- **Identify** SI units and symbols for length, volume, mass, density, time, and temperature.
- **Convert** related SI units.

### Why It's Important

By using uniform standards, nations can exchange goods and compare information easily.

### Review Vocabulary

**measurement:** the dimensions, capacity, or amount of something

### New Vocabulary

- standard
- SI
- volume
- mass
- density

**Figure 9** Hands are a convenient measuring tool, but using them can lead to misunderstanding.



## Units and Standards

A **standard** is an exact quantity that people agree to use to compare measurements. Look at **Figure 9**. Suppose you and a friend want to make some measurements to find out whether a desk will fit through a doorway. You have no ruler, so you decide to use your hands as measuring tools. Using the width of his hands, your friend measures the doorway and says it is 8 hands wide. Using the width of your hands, you measure the desk and find it is  $7\frac{3}{4}$  hands wide. Will the desk fit through the doorway? You can't be sure. What went wrong? Even though you both used hands to measure, you didn't check to see whether your hands were the same width as your friend's. In other words, you didn't use a measurement standard, so you can't compare the measurements.

## Measurement Systems

Suppose the label on a ball of string indicates that the length of the string is 150. Is the length 150 feet, 150 m, or 150 cm? For a measurement to make sense, it must include a number and a unit.

Your family might buy lumber by the foot, milk by the gallon, and potatoes by the pound. These measurement units are part of the English system of measurement, which is commonly used in the United States. Most other nations use the metric system—a system of measurement based on multiples of ten.

**International System of Units** In 1960, an improved version of the metric system was devised. Known as the International System of Units, this system is often abbreviated SI, from the French *Le Systeme Internationale d'Unites*. All **SI** standards are universally accepted and understood by scientists throughout the world. The standard kilogram, which is kept in Sèvres, France, is shown in **Figure 10**. All kilograms used throughout the world must be exactly the same as the kilogram kept in France.

Each type of SI measurement has a base unit. The meter is the base unit of length. Every type of quantity measured in SI has a symbol for that unit. These names and symbols for the seven base units are shown in **Table 1**. All other SI units are obtained from these seven units.



**Figure 10** The standard for mass, the kilogram, and other standards are kept at the International Bureau of Weights and Measures in Sèvres, France. **Explain** the purpose of a standard.

**SI Prefixes** The SI system is easy to use because it is based on multiples of ten. Prefixes are used with the names of the units to indicate what multiple of ten should be used with the units. For example, the prefix *kilo-* means “1,000.” That means that one kilometer equals 1,000 meters. Likewise, one kilogram equals 1,000 grams. Because *deci-* means “one-tenth,” one decimeter equals one tenth of a meter. A decigram equals one tenth of a gram. The most frequently used prefixes are shown in **Table 2**.

**Reading Check** How many meters is 1 km? How many grams is 1 dg?

Table 1 SI Base Units		
Quantity Measured	Unit	Symbol
Length	meter	m
Mass	kilogram	kg
Time	second	s
Electric current	ampere	A
Temperature	kelvin	K
Amount of substance	mole	mol
Intensity of light†	candela	cd

Table 2 Common SI Prefixes		
Prefix	Symbol	Multiplying Factor
Kilo-	k	1,000
Deci-	d	0.1
Centi-	c	0.01
Milli-	m	0.001
Micro-	μ	0.000 001
Nano-	n	0.000 000 001



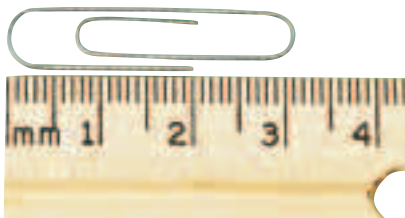

**Figure 11** One centimeter contains 10 mm.

**Measure** the length of the paper clip.

**Converting Between SI Units** Sometimes quantities are measured using different units. A conversion factor is a ratio that is equal to one and is used to change one unit to another. For example, there are 1,000 mL in 1 L, so  $1,000 \text{ mL} = 1 \text{ L}$ . If both sides in this equation are divided by 1 L, the equation becomes:

$$\frac{1,000 \text{ mL}}{1 \text{ L}} = 1$$

To convert units, you multiply by the appropriate conversion factor. For example, to convert 1.255 L to mL, multiply 1.255 L by a conversion factor. Use the conversion factor with new units (mL) in the numerator and the old units (L) in the denominator.

$$1.255 \text{ L} \times \frac{1,000 \text{ mL}}{1 \text{ L}} = 1,255 \text{ mL}$$

The unit L cancels in this equation, just as if it were a number.

## Applying Math Convert Units

**CALCULATING CENTIMETERS** How long in centimeters is a 3,075 mm rope?

**IDENTIFY** known values and the unknown value

Identify the known values:

The rope measures 3,075 mm;  $1 \text{ m} = 100 \text{ cm} = 1,000 \text{ mm}$

Identify the unknown value:

How long is the rope in cm?

**SOLVE** the problem

This is the equation you need to use:

$$? \text{ cm} = 3,075 \text{ mm} \times \frac{100 \text{ cm}}{1,000 \text{ mm}}$$

Cancel units and multiply:

$$3,075 \text{ mm} \times \frac{100 \text{ cm}}{1,000 \text{ mm}} = 307.5 \text{ cm}$$

**CHECK** your answer

Does your answer seem reasonable? Check your answer by multiplying the answer by  $\frac{1,000 \text{ mm}}{100 \text{ cm}}$ . Did you calculate the original length in millimeters?

### Practice Problems

- Your pencil is 11 cm long. How long is it in millimeters?
- The Bering Land Bridge National Preserve is a summer home to birdlife. Some birds migrate 20,000 miles. Assume 1 mile equals 1.6 kilometers. Calculate the distance birds fly in kilometers.

For more practice problems go to page 834, and visit [gpscience.com/extra\\_problems](http://gpscience.com/extra_problems).

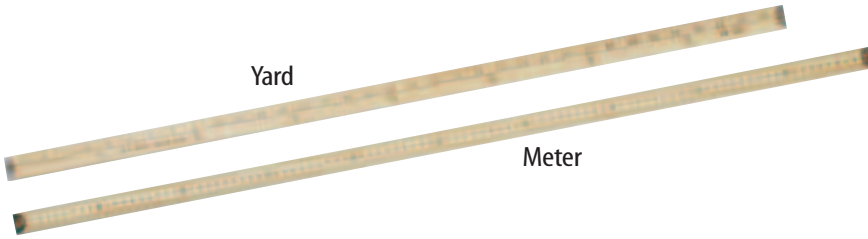

## Measuring Distance

The word *length* is used in many different ways. For example, the length of a novel is the number of pages or words it contains. In scientific measurement, however, length is the distance between two points. That distance might be the diameter of a hair or the distance from Earth to the Moon. The SI base unit of length is the meter, m. A baseball bat is about 1 m long. Metric rulers and metersticks are used to measure length. **Figure 12** compares a meter and a yard.

**Choosing a Unit of Length** As shown in **Figure 13**, the size of the unit you measure with will depend on the size of the object being measured. For example, the diameter of a shirt button is about 1 cm. You probably also would use the centimeter to measure the length of your pencil and the meter to measure the length of your classroom. What unit would you use to measure the distance from your home to school? You probably would want to use a unit larger than a meter. The kilometer, km, which is 1,000 m, is used to measure these kinds of distances.

By choosing an appropriate unit, you avoid large-digit numbers and numbers with many decimal places. Twenty-one kilometers is easier to deal with than 21,000 m. And 13 mm is easier to use than 0.013 m.

**Figure 13** The size of the object being measured determines which unit you will measure in. A tape measure measures in meters. The micrometer, shown at the left, measures in small lengths. **State** what unit you think it measures in.



**Figure 12** One meter is slightly longer than 1 yard and 100 m is slightly longer than a football field. **Predict** whether your time for a 100-m dash would be slightly more or less than your time for a 100-yard dash.



**Astronomical Units** The standard measurement for the distance from Earth to the Sun is called the astronomical unit, AU. The distance is about 150 billion ( $1.5 \times 10^{11}$ ) m. In your Science Journal, calculate what 1 AU would equal in km.







### Topic: International System of Units

Visit [gpscience.com](http://gpscience.com) for Web links to information about the International System of Units.

**Activity** Measure four different things in your classroom using a different unit—distance, volume, time, or temperature—for each. Use each unit only once. Write the measurements down and using the common prefixes in **Table 2**, convert them to different units.

## Measuring Volume

The amount of space occupied by an object is called its **volume**. If you want to know the volume of a solid rectangle, such as a brick, you measure its length, width, and height and multiply the three numbers and their units together ( $V = l \times w \times h$ ). For a brick, your measurements probably would be in centimeters. The volume would then be expressed in cubic centimeters,  $\text{cm}^3$ . To find out how much a moving van can carry, your measurements probably would be in meters, and the volume would be expressed in cubic meters,  $\text{m}^3$ , because when you multiply you add exponents.

**Measuring Liquid Volume** How do you measure the volume of a liquid? A liquid has no sides to measure. In measuring a liquid's volume, you are indicating the capacity of the container that holds that amount of liquid. The most common units for expressing liquid volumes are liters and milliliters. These are measurements used in canned and bottled foods. A liter occupies the same volume as a cubic decimeter,  $\text{dm}^3$ . A cubic decimeter is a cube that is 1 dm, or 10 cm, on each side, as in **Figure 14**.

Look at **Figure 14**. One liter is equal to 1,000 mL. A cubic decimeter,  $\text{dm}^3$ , is equal to 1,000  $\text{cm}^3$ . Because  $1 \text{ L} = 1 \text{ dm}^3$ , it follows that:

$$1 \text{ mL} = 1 \text{ cm}^3$$

Sometimes, liquid volumes such as doses of medicine are expressed in cubic centimeters.

Suppose you wanted to convert a measurement in liters to cubic centimeters. You use conversion factors to convert L to mL and then mL to  $\text{cm}^3$ .

$$1.5 \text{ L} \times \frac{1,000 \text{ mL}}{1 \text{ L}} \times \frac{1 \text{ cm}^3}{1 \text{ mL}} = 1,500 \text{ cm}^3$$

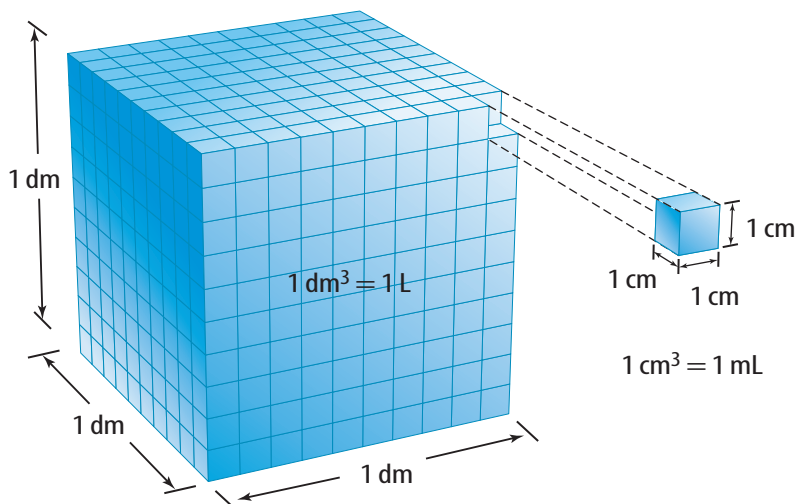

**Figure 14** The large cube has a volume of  $1 \text{ dm}^3$ , which is equivalent to 1 L.

**Calculate** the cubic centimeters ( $\text{cm}^3$ ) in the large cube.



**Table 3 Densities of Some Materials at 20°C**

Material	Density (g/cm <sup>3</sup> )	Material	Density (g/cm <sup>3</sup> )
hydrogen	0.000 09	aluminum	2.7
oxygen	0.001 4	iron	7.9
water	1.0	gold	19.3

## Measuring Matter

A table-tennis ball and a golf ball have about the same volume. But if you pick them up, you notice a difference. The golf ball has more mass. **Mass** is a measurement of the quantity of matter in an object. The mass of the golf ball, which is about 45 g, is almost 18 times the mass of the table-tennis ball, which is about 2.5 g. A bowling ball has a mass of about 5,000 g. This makes its mass roughly 100 times greater than the mass of the golf ball and 2,000 times greater than the table-tennis ball's mass. To visualize SI units, see **Figure 15** on the following page.

**Density** A cube of polished aluminum and a cube of silver that are the same size not only look similar but also have the same volume. The mass and volume of an object can be used to find the density of the material the object is made of. **Density** is the mass per unit volume of a material. You find density by dividing an object's mass by the object's volume. For example, the density of an object having a mass of 10 g and a volume of 2 cm<sup>3</sup> is 5 g/cm<sup>3</sup>. **Table 3** lists the densities of some familiar materials.

**Derived Units** The measurement unit for density, g/cm<sup>3</sup>, is a combination of SI units. A unit obtained by combining different SI units is called a derived unit. An SI unit multiplied by itself also is a derived unit. Thus the liter, which is based on the cubic decimeter, is a derived unit. A meter cubed, expressed with an exponent—m<sup>3</sup>—is a derived unit.

## Measuring Time and Temperature

It is often necessary to keep track of how long it takes for something to happen, or whether something heats up or cools down. These measurements involve time and temperature.

Time is the interval between two events. The SI unit for time is the second. In the laboratory, you will use a stopwatch or a clock with a second hand to measure time.

### Mini LAB

#### Determining the Density of a Pencil

**Procedure**  

1. Find a **pencil** that will fit in a 100-mL graduated cylinder below the 90-mL mark.
2. Measure the mass of the pencil in grams.
3. Put 90 mL of **water** (initial volume) into a 100-mL **graduated cylinder**. Lower the pencil, eraser first, into the cylinder. Push the pencil down until it is just submerged. Hold it there and record the final volume to the nearest tenth of a milliliter.

#### Analysis

1. Determine the water displaced by the pencil by subtracting the initial volume from the final volume.
2. Calculate the pencil's density by dividing its mass by the volume of water displaced.
3. Is the density of the pencil greater than or less than the density of water? How do you know?

**Figure 15**

**T**he characteristics of most of these everyday objects are measured using an international system known as SI dimensions. These dimensions measure length, volume, mass, density, and time. Celsius is not an SI unit but is widely used in scientific work.



**MILLIMETERS** A dime is about 1 mm thick.

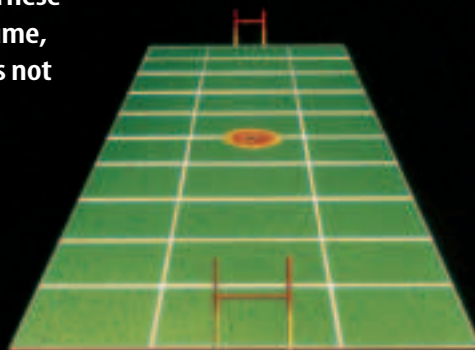

**METERS** A football field is about 91 m long.



**KILOMETERS** The distance from your house to a store can be measured in kilometers.



**LITERS** This carton holds 1.98 L of frozen yogurt.



**MILLILITERS** A teaspoonful of medicine is about 5 mL.



**GRAMS/METER** This stone sinks because it is denser—has more grams per cubic meter—than water.



**GRAMS** The mass of a thumbtack and the mass of a textbook can be expressed in grams.

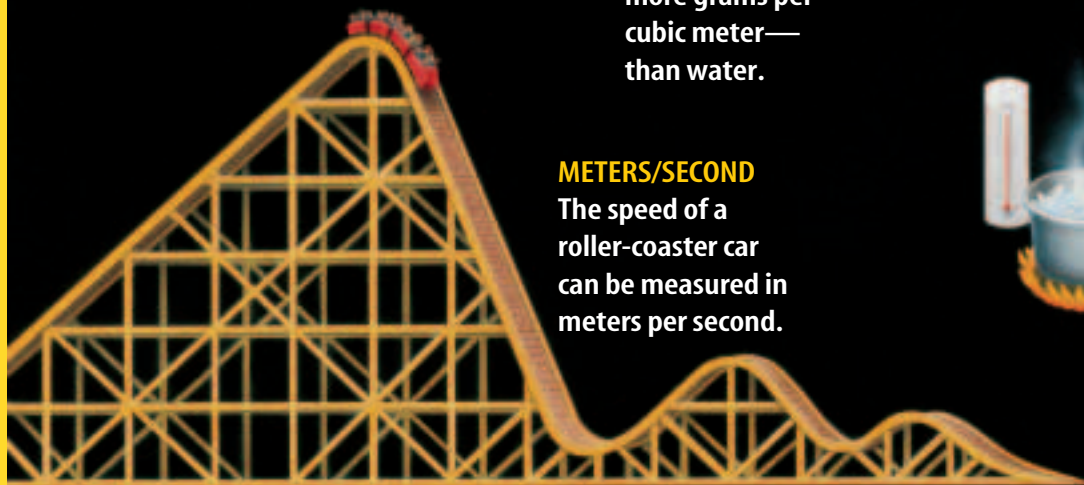

**METERS/SECOND** The speed of a roller-coaster car can be measured in meters per second.



**CELSIUS** Water boils at 100°C and freezes at 0°C.



**What's Hot and What's Not** You will learn the scientific meaning of the word *temperature* in a later chapter. For now, think of temperature as a measure of how hot or how cold something is.

Look at **Figure 16**. For most scientific work, temperature is measured on the Celsius (C) scale. On this scale, the freezing point of water is  $0^{\circ}\text{C}$ , and the boiling point of water is  $100^{\circ}\text{C}$ . Between these points, the scale is divided into 100 equal divisions. Each one represents  $1^{\circ}\text{C}$ . On the Celsius scale, average human body temperature is  $37^{\circ}\text{C}$ , and a typical room temperature is between  $20^{\circ}\text{C}$  and  $25^{\circ}\text{C}$ .

**Kelvin and Fahrenheit** The SI unit of temperature is the kelvin (K). Zero on the Kelvin scale (0 K) is the coldest possible temperature, also known as absolute zero. Absolute zero is equal to  $-273^{\circ}\text{C}$ , which is  $273^{\circ}$  below the freezing point of water.

Most laboratory thermometers are marked only with the Celsius scale. Because the divisions on the two scales are the same size, the Kelvin temperature can be found by adding 273 to the Celsius reading. So, on the Kelvin scale, water freezes at 273 K and boils at 373 K. Notice that degree symbols are not used with the Kelvin scale.

The temperature measurement you are probably most familiar with is the Fahrenheit scale, which was based roughly on the temperature of the human body,  $98.6^{\circ}$ .

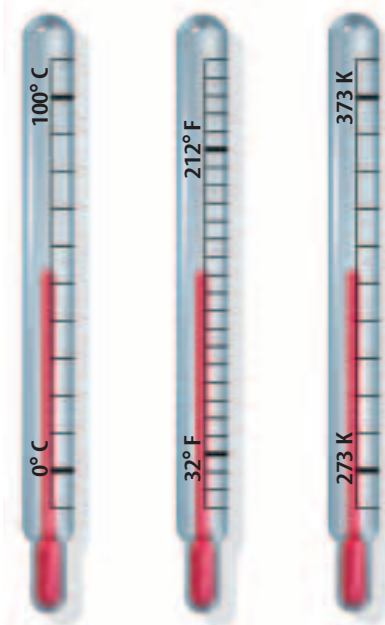

**Figure 16** These three thermometers illustrate the scales of temperature between the freezing and boiling points of water.

**Compare** the boiling points of the three scales.

**Reading Check**

*What is the relationship between the Celsius scale and the Kelvin scale?*

section **2** review

**Summary**

**Units and Standards**

- When making measurements, it is important to be accurate.

**Measurement Systems**

- The International System of Units, or SI, was established to provide a standard of measurement and reduce confusion.
- Conversion factors are used to change one unit to another and involve using a ratio equal to 1.

**Measuring**

- The size of an object being measured determines which unit you will measure in.

**Self Check**

1. **Explain** why it is important to have exact standards of measurement.
2. **Explain** why density is a derived unit.
3. **Think Critically** Using a metric ruler, measure a shoe box and a pad of paper. Find the volume of each in cubic centimeters. Then convert the units to mL.

**Applying Math**

4. **Convert Units** Make the following conversions:  $27^{\circ}\text{C}$  to Kelvin, 20 dg to milligrams, and 3 m to decimeters.
5. **Calculate Density** What is the density of an unknown metal that has a mass of 158 g and a volume of 20 mL? Use **Table 3** to identify this metal.

# Communicating with Graphs

## Reading Guide

### What You'll Learn

- **Identify** three types of graphs and explain the ways they are used.
- **Distinguish** between dependent and independent variables.
- **Analyze** data using the various types of graphs.

### Why It's Important

Graphs are a quick way to communicate a lot of information in a small amount of space.

### Review Vocabulary

**data:** information gathered during an investigation or observation

### New Vocabulary

- graph

**Figure 17** This graph tells the story of the motion that takes place when a girl takes her dog for an 8-min walk.

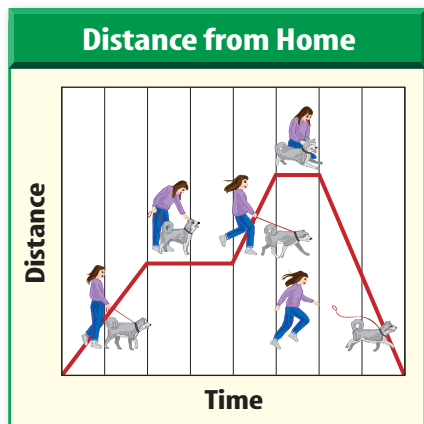

## A Visual Display

Scientists often graph the results of their experiments because they can detect patterns in the data easier in a graph than in a table. A **graph** is a visual display of information or data. **Figure 17** is a graph that shows a girl walking her dog. The horizontal axis, or the *x*-axis, measures time. Time is the independent variable because as it changes, it affects the measure of another variable. The distance from home that the girl and the dog walk is the other variable. It is the dependent variable and is measured on the vertical axis, or *y*-axis.

Graphs are useful for displaying numerical information in business, science, sports, advertising, and many everyday situations. Different kinds of graphs—line, bar, and circle—are appropriate for displaying different types of information.

### Reading Check What are three common types of graphs?

Graphs are useful for displaying numerical information in business, science, sports, advertising, and many other everyday situations. Graphs make it easier to understand complex patterns by displaying data in a visual manner. Scientists often graph their data to detect patterns that would not have been evident in a table. Different graphs use a different methods for displaying information. The conclusions drawn from graphs must be based on accurate information and reasonable scales.

## Line Graphs

A line graph can show any relationship where the dependent variable changes due to a change in the independent variable. Line graphs often show how a relationship between variables changes over time. You can use a line graph to track many things, such as how certain stocks perform or how the population changes over any period of time—a month, a week, or a year.

You can show more than one event on the same graph as long as the relationship between the variables is identical. Suppose a builder had three choices of thermostats for a new school. He wanted to test them to know which was the best brand to install throughout the building. He installed a different thermostat in classrooms A, B, and C. He set each thermostat at 20°C. He turned the furnace on and checked the temperatures in the three rooms every 5 min for 25 min. He recorded his data in **Table 4**.

The builder then plotted the data on a graph. He could see from the table that the data did not vary much for the three classrooms. So he chose small intervals for the  $y$ -axis and left part of the scale out (the part between 0° and 15°). See **Figure 18**. This allowed him to spread out the area on the graph where the data points lie. You can see easily the contrast in the colors of the three lines and their relationship to the black horizontal line. The black line represents the thermostat setting and is the control. The control is what the resulting room temperature of the classrooms should be if the thermostats are working efficiently.

**Table 4 Room Temperature**

Time*	Classroom Temperature (C°)		
	A	B	C
0	16	16	16
5	17	17	16.5
10	19	19	17
15	20	21	17.5
20	20	23	18
25	20	25	18.5

\*minutes after turning on heat

**Figure 18** The room temperatures of classrooms A, B, and C are shown in contrast to the thermostat setting of 20°C. **Identify** the thermostat that achieved its temperature setting the quickest.

The break in the vertical axis between 0 and 15 means that numbers in this range are left out. This leaves room to spread the scale where the data points lie, making the graph easier to read.

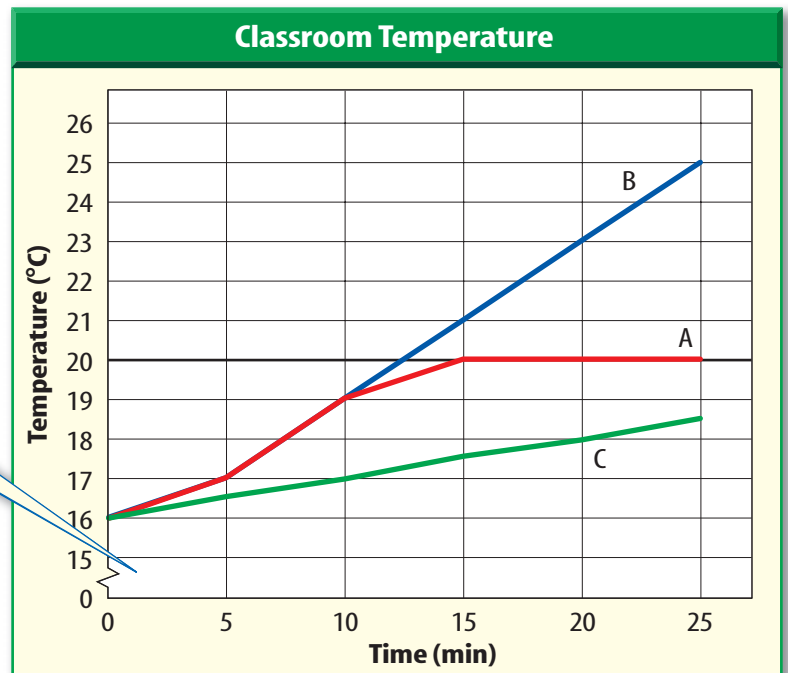





**Figure 19** Graphing calculators are valuable tools for making graphs.

**Constructing Line Graphs** Besides choosing a scale that makes a graph readable, as illustrated in **Figure 18**, other factors are involved in constructing useful graphs. The most important factor in making a line graph is always using the  $x$ -axis for the independent variable. The  $y$ -axis always is used for the dependent variable. Because the points in a line graph are related, you connect the points.

Another factor in constructing a graph involves units of measurement. For example, you might use a Celsius thermometer for one part of your experiment and a Fahrenheit thermometer for another. But you must first convert your temperature readings to the same unit of measurement before you make your graph.

In the past, graphs had to be made by hand, with each point plotted individually. Today, scientists use a variety of tools, such as computers and graphing calculators like the one shown in **Figure 19**, to help them draw graphs.

## Applying Math Make and Use Graphs

**GRAPHING TEMPERATURE** In an experiment, you checked the air temperature at certain hours of the day. At 8 A.M., the temperature is  $27^{\circ}\text{C}$ ; at noon, the temperature is  $32^{\circ}\text{C}$ ; and at 4 P.M., the temperature is  $30^{\circ}\text{C}$ . Graph the results of your experiment.

**IDENTIFY** known values

time = independent variable which is the  $x$ -axis

temperature = dependent variable which is the  $y$ -axis

**GRAPH** the problem

Graph time on the  $x$ -axis and temperature on the  $y$ -axis. Mark the equal increments on the graph to include all measurements. Plot each point on the graph by finding the time on the  $x$ -axis and moving up until you find the recorded temperature on the  $y$ -axis. Place a point there. Continue placing points on the graph. Then connect the points from left to right.

### Practice Problems

As you train for a marathon, you compare your previous times. In year one, you ran it in 5.2 h; in year two, you ran it in 5 h; in year three, you ran it in 4.8 h; in year four, you ran it in 4.3 h; and in year five, you ran it in 4 h.

1. Make a table of your data.
2. Graph the results of your marathon races.
3. Calculate your percentage of improvement from year 1 to year 5.

For more practice problems, go to page 834, and visit [gpscience.com/extra\\_problems](http://gpscience.com/extra_problems).

## Bar Graphs

A bar graph is useful for comparing information collected by counting. For example, suppose you counted the number of students in every classroom in your school on a particular day and organized your data as in **Table 5**. You could show these data in a bar graph like the one shown in **Figure 20**. Uses for bar graphs include comparisons of oil, or crop productions, costs, or as data in promotional materials. Each bar represents a quantity counted at a particular time, which should be stated on the graph. As on a line graph, the independent variable is plotted on the  $x$ -axis and the dependent variable is plotted on the  $y$ -axis.

Recall that you might need to place a break in the scale of the graph to better illustrate your results. For example, if your data were 1,002, 1,010, 1,030, and 1,040 and the intervals on the scale were every 100 units, you might not be able to see the difference from one bar to another. If you had a break in the scale and started your data range at 1,000 with intervals of ten units, you could make a more accurate comparison.

**Reading Check** Describe possible data where using a bar graph would be better than using a line graph.

Table 5 Classroom Size	
Number of Students	Number of Classrooms
20	1
21	3
22	3
23	2
24	3
25	5
26	5
27	3

**Figure 20** The height of each bar corresponds to the number of classrooms having a particular number of students.

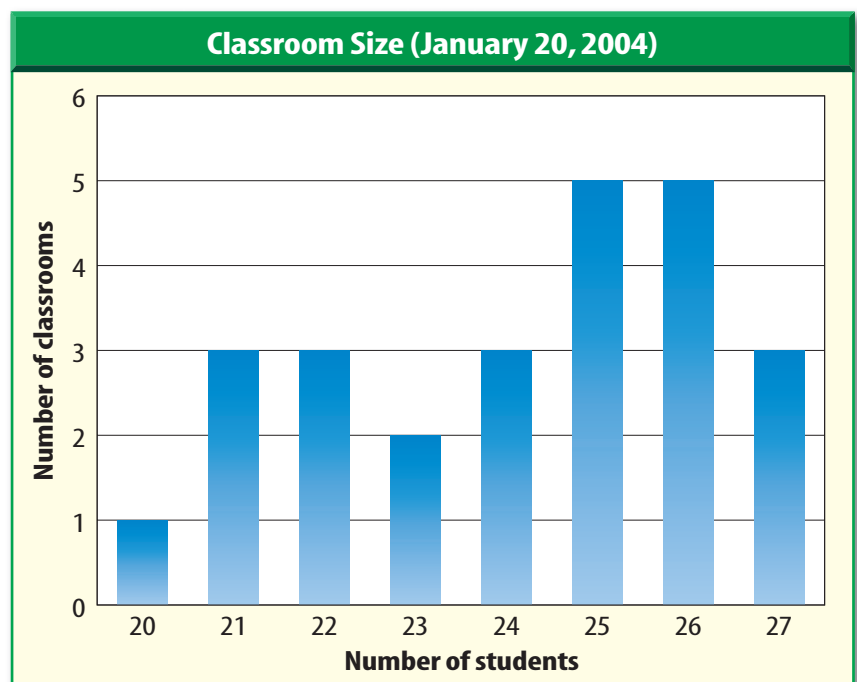

## Mini LAB

### Observing Change Through Graphing

**Procedure**

1. Place a **thermometer** in a **plastic foam cup** of hot, but not boiling, **water**.
2. Measure and record the temperature every 30 s for 5 min.
3. Repeat the experiment with freshly heated water. This time, cover the cup with a **plastic lid** in between measurements.

### Analysis

1. Make a line graph of the changing temperature from step 2, showing time on the  $x$ -axis and temperature on the  $y$ -axis. Using a different color pen, plot the changing temperature from step 3 on the same graph.
2. Use the graph to describe the cooling process in each of the trials.



Heating Fuel Usage

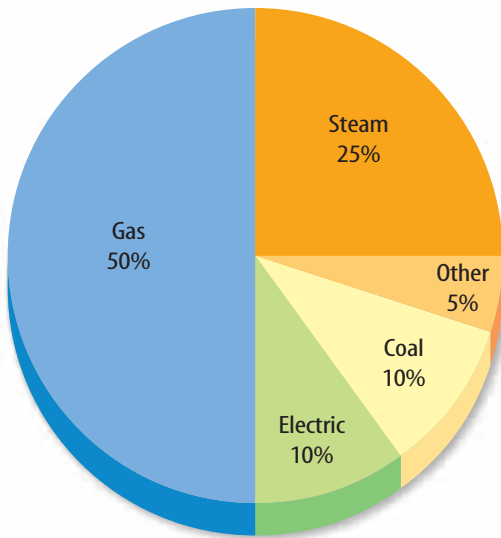

**Figure 21** A circle graph shows the different parts of a whole quantity.

## Circle Graphs

A circle graph, or pie graph, is used to show how some fixed quantity is broken down into parts. The circular pie represents the total. The slices represent the parts and usually are represented as percentages of the total.

**Figure 21** illustrates how a circle graph could be used to show the percentage of buildings in a neighborhood using each of a variety of heating fuels. You easily can see that more buildings use gas heat than any other kind of system. What else does the graph tell you?

To create a circle graph, you start with the total of what you are analyzing. **Figure 21** starts with 72 buildings in the neighborhood. For each type of heating fuel, you divide the number of buildings using each type of fuel by the total (72). You then multiply that decimal by  $360^\circ$  to determine the angle that the decimal makes in the circle. Eighteen buildings use steam. Therefore,  $18 \div 72 \times 360^\circ = 90^\circ$  on the circle graph. You then would measure  $90^\circ$  on the circle with your protractor to show 25 percent.

When you use graphs, think carefully about the conclusions you can draw from them. You want to make sure your conclusions are based on accurate information and that you use scales that help make your graph easy to read.

### section 3 review

#### Summary

##### A Visual Display

- Graphs are a visual representation of data.
- Scientists often graph their data to detect patterns.
- The type of graph used is based on the conclusions you want to identify.

##### Line Graphs

- A line graph shows how a relationship between two variables changes over time.

##### Bar Graphs

- Bar graphs are best used to compare information collected by counting.

##### Circle Graphs

- A circle graph shows how a fixed quantity is broken down into parts.

#### Self Check

1. **Identify** the kind of graph that would best show the results of a survey of 144 people where 75 ride a bus, 45 drive cars, 15 carpool, and 9 walk to work.
2. **State** which type of variable is plotted on the  $x$ -axis and which type is plotted on the  $y$ -axis.
3. **Explain** why the points in a line graph are connected.
4. **Think Critically** How are line, bar, and circle graphs similar? How are they different?

#### Applying Math

5. **Percentage** In a survey, it was reported that 56 out of 245 people would rather drink orange juice in the morning than coffee. Calculate what percentage of a circle graph this data would occupy.



## Converting Kitchen Measurements

Look through a recipe book. Are any of the ingredient amounts stated in SI? How can you convert English measurements to SI measurements?

### Real-World Question

How do kitchen measurements compare with SI measurements?

#### Goals

- Determine a relationship between two systems of measurements.
- Calculate the conversion factors for converting English units to SI units.

#### Materials

balance	dried beans
100-mL graduated cylinder	dried rice
measuring cup	potato flakes
measuring teaspoon	water
measuring tablespoon	vinegar
cornmeal	salad oil

#### Safety Precautions



### Procedure

1. Copy the data table into your Science Journal and record each SI measurement.
2. Use the appropriate English measuring cup or spoon to measure the amounts of each ingredient shown in the table.
3. Use a balance to measure each dry ingredient. Use a graduated cylinder to measure each liquid ingredient.

#### English to SI Conversions

Ingredient	English Measure	SI Measure
Water	1/2 cup	
Cornmeal	2 cups	
Salad oil	4 tablespoons	<b>Do not write in this book.</b>
Dried rice	1/2 cup	
Potato flakes	3 cups	
Vinegar	1 teaspoon	
Dried beans	3 cups	

### Conclude and Apply

1. **Calculate** the number of grams in one cup of each dry ingredient. Calculate the number of milliliters in one cup, one teaspoon, and one tablespoon of each liquid ingredient.
2. **Write** conversion factors that will convert each English unit to an SI unit for each ingredient.
3. **Calculate** how many milliliters you would measure if a recipe called for three tablespoons of salad oil.
4. **Compare and contrast** your conversion factors for the dry ingredients and your conversion factors for the liquid ingredients.

#### Communicating Your Data

Write a recipe used in your home converting all the English units to SI units.

# Setting High Standards for Measurements

## Real-World Question

To develop the International System of Units, people had to agree on set standards and basic definitions of scale. If you had to develop a new measurement system, people would have to agree with your new standards and definitions. In this activity, your team will use string to devise and test its own SI (String International) system for measuring length. What are the requirements for designing a new measurement system using string?

## Form a Hypothesis

Based on your knowledge of measurement standards and systems, form a hypothesis that explains how exact units help keep measuring consistent.

## Test Your Hypothesis

### Make a Plan

1. As a group, agree upon and write out the hypothesis statement.
2. As a group, list the steps that you need to take to test your hypothesis. Be specific, describing exactly what you will do at each step.
3. Make a list of the materials that you will need.

### Goals

- **Design** an experiment that involves devising and testing your own measurement system for length.
- **Measure** various objects with the string measurement system.

### Possible Materials

string  
scissors  
marking pen  
masking tape  
miscellaneous objects for standards

### Safety Precautions



## Using Scientific Methods

4. **Design** a data table in your Science Journal so it is ready to use as your group collects data.
5. As you read over your plan, be sure you have chosen an object in your classroom to serve as a standard. It should be in the same size range as what you will measure.
6. Consider how you will mark scale divisions on your string. Plan to use different pieces of string to try different-sized scale divisions.
7. What is your new unit of measurement called? Come up with an abbreviation for your unit. Will you name the smaller scale divisions?
8. What objects will you measure with your new unit? Be sure to include objects longer and shorter than your string. Will you measure each object more than once to test consistency? Will you measure the same object as another group and compare your findings?

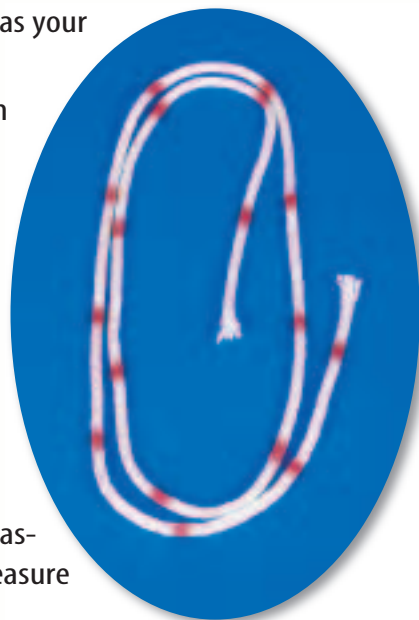

### Follow Your Plan

1. Make sure your teacher approves your plan before you start.
2. Carry out the experiment as it has been planned.
3. **Record** observations that you make and complete the data table in your Science Journal.

### Analyze Your Data

1. Which of your string scale systems will provide the most accurate measurement of small objects? Explain.
2. How did you record measurements that were between two whole numbers of your units?

### Conclude and Apply

1. When sharing your results with other groups, why is it important for them to know what you used as a standard?
2. **Infer** how it is possible for different numbers to represent the same length of an object.

### Communicating Your Data

**Compare** your conclusions with other students' conclusions. Are there differences? Explain how these may have occurred.



## Thinking in Pictures: and other reports from my life with autism<sup>1</sup>

By Temple Grandin



*Temple Grandin is an animal scientist and writer who also happens to be autistic. People with autism are said to think in pictures.*

I think in pictures. Words are like a second language to me. I translate both spoken and written words into full-color movies, complete with sound, which run like a VCR tape in my head. When somebody speaks to me, his words are instantly translated into pictures. Language-based thinkers often find this phenomenon difficult to understand, but in my job as equipment designer for the livestock industry, visual thinking is a tremendous advantage.

... I credit my visualization abilities with helping me understand the animals I work with. Early in my career I used a camera to help give me the animals' perspective as they walked through a chute for their veterinary treatment. I would kneel down and take pictures through the chute from the cow's eye level. Using the photos, I was able to figure out which things scared the cattle.

Every design problem I've ever solved started with my ability to visualize and see the world in pictures. I started designing things as a child, when I was always experimenting with new kinds of kites and model airplanes.

1 Autism is a complex developmental disability that usually appears during the first three years of life. Children and adults with autism typically have difficulties in communicating with others and relating to the outside world.

### Understanding Literature

**Identifying the Main Idea** The most important idea expressed in a paragraph or essay is the main idea. The main idea in a reading might be clearly stated, but sometimes the reader has to summarize the contents of a reading in order to determine its main idea. What do you think is the main idea of the passage?

### Respond to the Reading

1. How do people with autism think differently than other people?
2. What did the author use to see from a cow's point of view?
3. What did the author use for models to design things when she was a child?
4. **Linking Science and Writing** Research the use of a scientific model. Write a paragraph stating the main ideas and listing supporting details.



Models enable scientists to see things that are too big, too small, or are too complex. Scientists might build models of DNA, airplanes, or other equipment. Temple Grandin's visual thinking and ability to make models enables her to predict how things will work when they are put together.

## Reviewing Main Ideas

**Section 1** The Methods of Science

1. Science is a way of learning about the natural world, such as the hurricane shown below, through investigation.

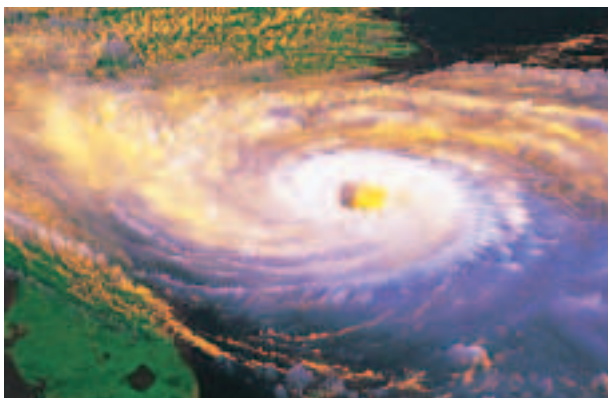

2. Scientific investigations can involve making observations, testing models, or conducting experiments.
3. Scientific experiments investigate the effect of one variable on another. All other variables are kept constant.
4. Scientific laws are repeated patterns in nature. Theories attempt to explain how and why these patterns develop.

**Section 2** Standards of Measurement

1. A standard of measurement is an exact quantity that people agree to use as a basis of comparison. The International System of Units, or SI, was established to provide a standard and reduce confusion.
2. When a standard of measurement is established, all measurements are compared to the same exact quantity—the standard. Therefore, all measurements can be compared with one another.

3. The most commonly used SI units include: length—meter, volume—liter, mass—kilogram, and time—second.
4. In SI, prefixes are used to make the base units larger or smaller by multiples of ten.
5. Any SI unit can be converted to any other related SI unit by multiplying by the appropriate conversion factor. These towers are 45,190 cm in height, which is equal to 451.9 m.

**Section 3**

## Communicating With Graphs

1. Graphs are a visual representation of data that make it easier for scientists to detect patterns.
2. Line graphs show continuous changes among related variables. Bar graphs are used to show data collected by counting. Circle graphs show how a fixed quantity can be broken into parts.
3. To create a circle graph, you have to determine the angles for your data.
4. In a line graph, the independent variable is always plotted on the horizontal  $x$ -axis. The dependent variable is always plotted on the vertical  $y$ -axis.

**FOLDABLES™**

Use the Foldable that you made at the beginning of this chapter to help you review scientific processes.

## Using Vocabulary

bias p.10	model p.11
constant p.9	scientific law p.12
control p.9	scientific method p.7
density p.19	SI p.15
dependent variable p.9	standard p.14
experiment p.8	technology p.13
graph p.22	theory p.12
hypothesis p.8	variable p.9
independent variable p.9	volume p.18
mass p.19	

Match each phrase with the correct term from the list of vocabulary words.

- the modern version of the metric system
- the amount of space occupied by an object
- an agreed-upon quantity used for comparison
- the amount of matter in an object
- a variable that changes as another variable changes
- a visual display of data
- a test set up under controlled conditions
- a variable that does NOT change as another variable changes
- mass per unit volume
- an educated guess using what you know and observe

## Checking Concepts

Choose the word or phrase that best answers the question.

- Which of the following questions CANNOT be answered by science?
  - How do birds fly?
  - Is this a good song?
  - What is an atom?
  - How does a clock work?

- Which of the following is an example of an SI unit?
  - foot
  - second
  - pound
  - gallon
- One one-thousandth is expressed by which prefix?
  - kilo-
  - nano-
  - centi-
  - milli-
- Which of the following is SI based on?
  - inches
  - powers of five
  - English units
  - powers of ten
- What is the symbol for deciliter?
  - dL
  - dcL
  - dkL
  - Ld
- Which of the following is NOT a derived unit?
  - $\text{dm}^3$
  - m
  - $\text{cm}^3$
  - g/ml
- Which of the following is NOT equal to 1,000 mL?
  - 1 L
  - 100 cL
  - 1  $\text{dm}^3$
  - 1  $\text{cm}^3$

## Interpreting Graphics

Use the photo below to answer question 18.



- The illustrations above show the items needed for an investigation. Which item is the independent variable? Which items are the constants? What might a dependent variable be?



19. Copy and complete this concept map on scientific methods.

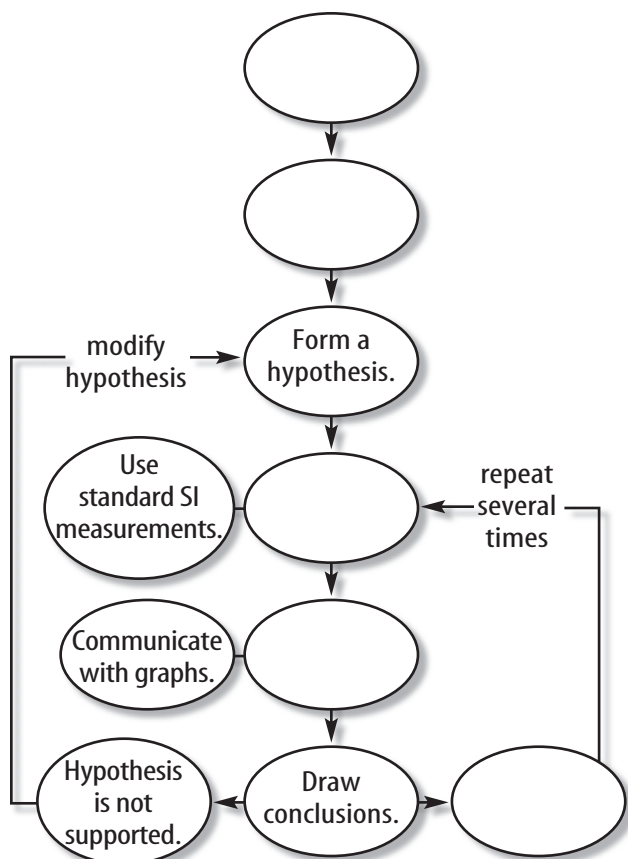

### Thinking Critically

20. **Communicate** Standards of measurement used during the Middle Ages often were based on such things as the length of the king's arm. How would you go about convincing people to use a different system of standard units?
21. **Analyze** What are some advantages and disadvantages of adopting SI in the United States?
22. **Identify** when bias occurs in scientific experimentation. Describe steps scientists can take to reduce bias and validate experimental data.

23. **Demonstrate** Not all objects have a volume that is measured easily. If you were to determine the mass, volume, and density of your textbook, a container of milk, and an air-filled balloon, how would you do it?
24. **Apply** Suppose you set a glass of water in direct sunlight for 2 h and measure its temperature every 10 min. What type of graph would you use to display your data? What would the dependent variable be? What would the independent variable be?
25. **Form a Hypothesis** A metal sphere is found to have a density of  $5.2 \text{ g/cm}^3$  at  $25^\circ\text{C}$  and a density of  $5.1 \text{ g/cm}^3$  at  $50^\circ\text{C}$ . Form a hypothesis to explain this observation. How could you test your hypothesis?
26. **List** the SI units of length you would use to express the following.  
 a. diameter of a hair  
 b. width of your classroom  
 c. width of a pencil lead  
 d. length of a sheet of paper
27. **Compare and contrast** the ease with which conversions can be made among SI units versus conversions among units in the English system.

### Applying Math

28. **Convert Units** Make the following conversions.  
 A) 1,500 mL to L      C) 5.8 dg to mg  
 B) 2 km to cm      D)  $22^\circ\text{C}$  to K
29. **Calculate the density** of an object having a mass of 17 g and a volume of  $3 \text{ cm}^3$ .
30. **Solve** A block of wood is 0.4 m by 0.2 m by 0.7 m. Find its dimensions in centimeters. Then find its volume in cubic centimeters.

## Part 1 Multiple Choice

Record your answers on the answer sheet provided by your teacher or on a sheet of paper.

Use the graph below to answer questions 1 and 2.

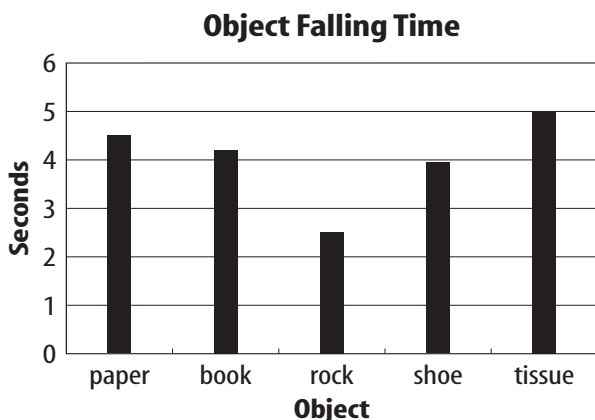

- Students drop objects from a height and measure the time it takes each to reach the ground. What is the dependent variable in this experiment?
  - falling time
  - shoe
  - drop height
  - paper
- What is a constant in this experiment?
  - throwing some objects and dropping others
  - measuring different falling times for each object
  - dropping each object from the same height
  - dropping a variety of objects
- Which of the following is a statement about something that happens in nature which seems to be true all the time?
  - theory
  - scientific law
  - hypothesis
  - conclusion

## Test-taking Tip

**Recheck Your Answers** Double check your answers before turning in the test.

- What does the symbol *ns* represent?
  - millisecond
  - nanosecond
  - microsecond
  - kelvin
- Which of these best defines mass?
  - the amount of space occupied by an object
  - the distance between two points
  - the quantity of matter in an object
  - the interval between two events

Use the graph below to answer questions 6 and 7.

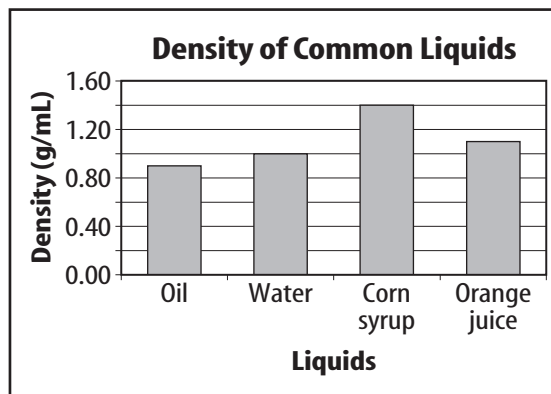

- Which two liquids have the highest and the lowest densities?
  - oil and water
  - oil and corn syrup
  - orange juice and water
  - corn syrup and orange juice
- What is the density of oil in units of  $\text{mg}/\text{cm}^3$ ?
  - $850 \text{ mg}/\text{cm}^3$
  - $85 \text{ mg}/\text{cm}^3$
  - $0.085 \text{ mg}/\text{cm}^3$
  - $8500 \text{ mg}/\text{cm}^3$
- Which type of graph is most useful for showing how the relationship between independent and dependent variables changes over time?
  - circle graph
  - bar graph
  - pictograph
  - line graph

## Part 2 Short Response/Grid In

Record your answers on the answer sheet provided by your teacher or on a sheet of paper.

9. Describe several ways scientists use investigations to learn about the natural world.
10. Define the term *technology*. Identify three ways that technology makes your life easier, safer, or more enjoyable.
11. Describe the three major categories into which science is classified. Which branches of science would be most important to an environmental engineer? Why?
12. Make the following conversions:
  - a. 615 mg to g
  - b. 75 dL to mL
  - c. 0.95 km to cm

Use the illustration below to answer questions 13 and 14.

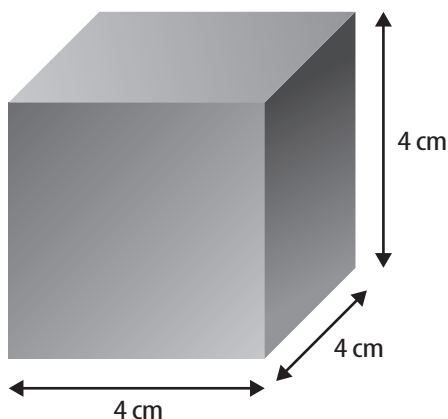

13. Define the term *volume*. Calculate the volume of the cube shown above. Give your answer in  $\text{cm}^3$  and mL.
14. Define the term *density*. If the mass of the cube is 96 g, what is the density of the cube material?
15. Why do scientists use graphs when analyzing data?

## Part 3 Open Ended

Record your answers on a sheet of paper.

16. A friend frequently misses the morning school bus. Use the scientific method to address this problem.

Use the illustration below to answer questions 17 and 18.



17. What is the standard unit shown in this picture? Why is it kept under cover, in a vacuum-sealed container?
18. Why is this standard important to anyone who makes measurements? Explain why valid experimental results must be based on standards.
19. You must decide what items to pack for a hiking and camping trip. Space is limited, and you must carry all items during hikes. What measurements are important in your preparation?

Use the table below to answer question 20.

Animal Life Span			
	Cow	Dog	Horse
Resting Heart Rate	52 beats per min	95 beats per min	48 beats per min
Average Life Span	18 years	16 years	27 years

20. Create a graph to display the data shown above.